

5000W - Vocarb

Filter Airborne Chemicals, Vapors, Gases, Odors as well as Smoke.

For stationary applications where is important to capture and retain airborne chemicals, vapors, odors, and smoke from oldering work stations.

5 stages filtration

- Pre-filter to capture large particles of dust.
- 99.97% Particulate, HEPA filter to capture respirable size particles, as small as 0.3 microns from smoke and dust.
- Large main carbon filters that holds 18 lbs. of special MAC-B activated carbon for adsorbing soldering fumes which can make you very ill.

Robust, all metal housing

- 15" diameter, 21.5" high all steel body to avoid plastic off-gasing.
- On easy glide casters.
- One person portable, weighs 45 lbs.

Flexibility

- By utilizing one standard 5"x6' flex hose the unit can be located close to work area in the best position to capture the fumes.
- Air volume draw is calculated not to influence the performance of the process that generates the fumes.
- Simply, plug into 115 V/60 Hz/1ph to work.

Powerful, low consumption motor

- 200 CFM free flow.
- 1 amp.



5000W - Vocarb

Also available:
5000 W-D with 22 lbs. of carbon

Reduce Gases, Odors and Smoke in the air you breathe

5000W - Vocarb

Filter and unit diagram



■ **Also available:**
5000 W-D with 22 lbs. of carbon

Kanaduct interlock Flex hose

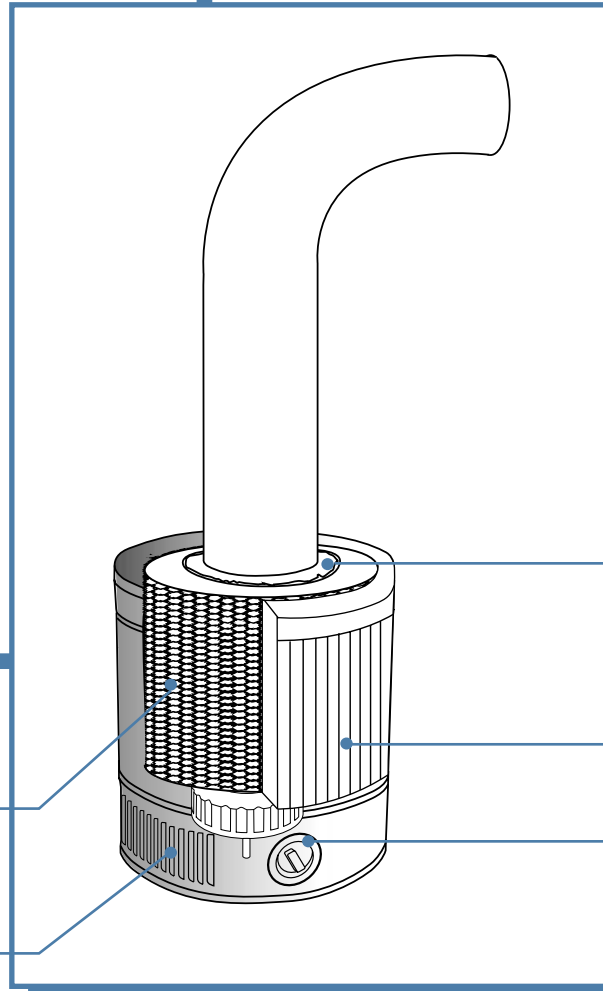

Pre-Filter

HEPA Filter

Speed Control

18 lbs. Carbon Canister

Clean Air Source